

### Features

- \* Low Forward Voltage Drop
- \* High Current Capability
- \* High Reliability
- \* High Surge Current Capability



RoHS  
COMPLIANT

### Package Outline Dimensions

DO-15:

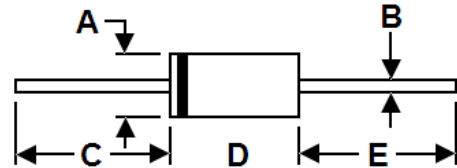

DIM.	Unit (mm)		Unit (inch)	
	Min	Max	Min	Max
A	2.6	3.6	0.102	0.142
B	0.7	0.9	0.027	0.035
C	25.4	-	1.0	-
D	5.8	7.6	0.228	0.300
E	25.4	-	1.0	-

### Mechanical Data

- \* Case: Molded plastic
- \* Epoxy: UL 94V-0 rate flame retardant
- \* Lead: Axial leads, solderable per MIL-STD-202, method 208 guaranteed
- \* Polarity: Color band denotes cathode end
- \* Mounting Position: Any

### Maximum Ratings and Electrical Characteristics

Rating at 25 °C ambient temperature unless otherwise specified. Single phase, half wave, 60 Hz, resistive or inductive load. For capacitive load, derate current by 20%.

Type Number	Symbol	FR 201G	FR 202G	FR 203G	FR 204G	FR 205G	FR 206G	FR 207G	Unit
Maximum Recurrent Peak Reverse Voltage	$V_{RRM}$	50	100	200	400	600	800	1000	V
Maximum RMS Voltage	$V_{RMS}$	35	70	140	280	420	560	700	V
Maximum D.C Blocking Voltage	$V_{DC}$	50	100	200	400	600	800	1000	V
Maximum Average Forward Rectified Current .375" (9.5mm)Lead Length @ $T_A=55^\circ C$	$I_{F(AV)}$	2.0							A
Peak Forward Surge Current, 8.3ms single half sine-wave superimposed on rated load(JEDEC method)	$I_{FSM}$	80							A
Maximum Instantaneous Forward Voltage at 2.0A	$V_F$	1.3							V
Maximum D.C Reverse Current @ $T_A=25^\circ C$ at Rated D.C Blocking Voltage @ $T_A=125^\circ C$	$I_R$	5.0 100							$\mu A$
Maximum Reverse Recovery Time(Note1)	$T_{rr}$	150			250	500		nS	
Typical Junction Capacitance(Note2)	$C_J$	35							pF
Operating and Storage Temperature Range	$T_J/T_{STG}$	-55 to +150							$^\circ C$

Note:1、 Reverse Recovery Test Conditions:  $I_F=0.5A$ ,  $I_R=1.0A$ ,  $I_{RR}=0.25A$ .    2、 Measured at 1MHz and Applied Reverse Voltage of 4.0V D.C.

### Ratings and Characteristic Curves

**FIG. 1 – TYPICAL FORWARD CURRENT DERATING CURVE**

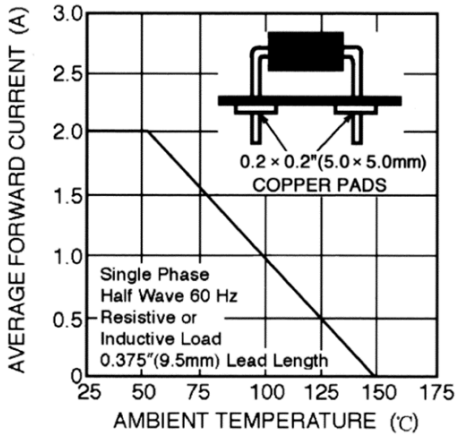

**FIG. 2 – MAXIMUM NON-REPETITIVE FORWARD SURGE CURRENT**

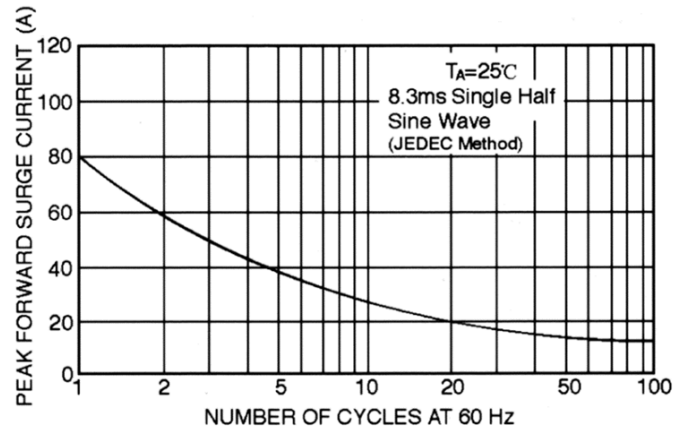

**FIG. 3 – TYPICAL FORWARD CHARACTERISTICS**

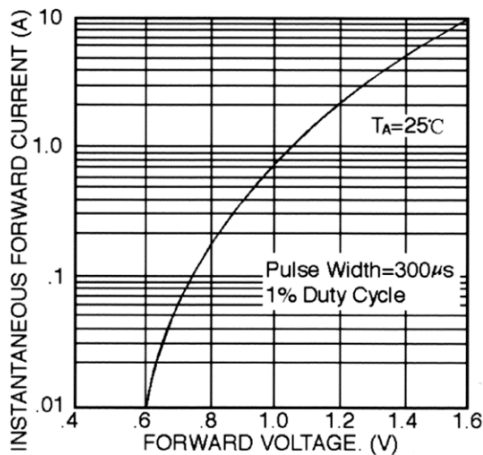

**FIG. 4 – TYPICAL JUNCTION CAPACITANCE**

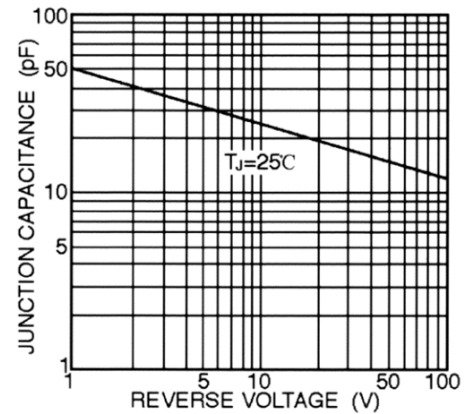

**FIG. 5 – TEST CIRCUIT DIAGRAM AND REVERSE RECOVERY TIME CHARACTERISTICS**

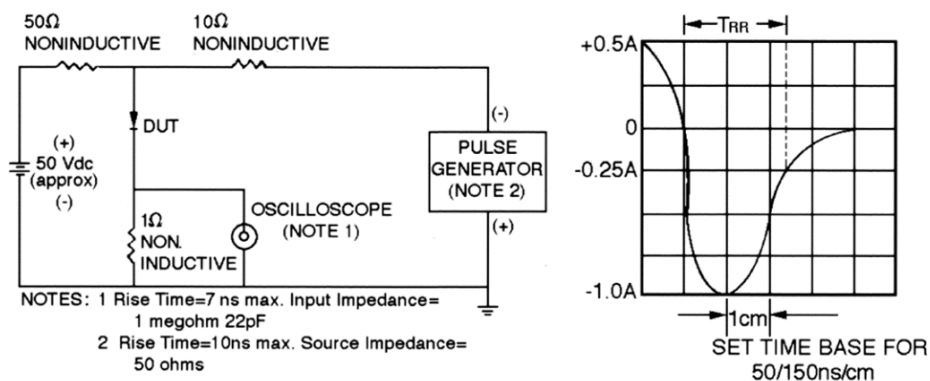



# FR201G THRU FR207G

2.0 Amps. Glass Passivated Fast Recovery Rectifiers

## Ordering Information

Part No.	Package	Packing
FR201G~FR207G	DO-15	2K/AMMO box
FR201G~FR207G	DO-15	3K/AMMO box
FR201G~FR207G	DO-15	4K/13" Paper reel
FR201G~FR207G	DO-15	0.5K/Bulk packing