

Features

- * Fast Switching Diode
- * Marking Code: "W2"

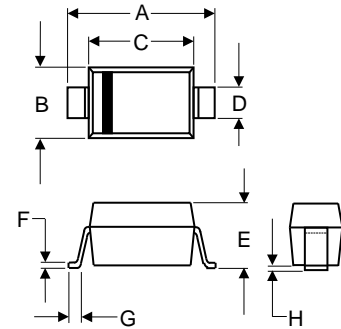

RoHS
COMPLIANT



SOD-323				
DIM	INCHES		MM	
	MIN	MAX	MIN	MAX
A	0.091	0.110	2.30	2.80
B	0.045	0.053	1.15	1.35
C	0.063	0.071	1.60	1.80
D	0.010	0.016	0.25	0.40
E	0.031	0.043	0.80	1.10
F	---	0.006	---	0.15
G	0.004	0.020	0.10	0.50
H	---	0.004	---	0.10

Maximum Ratings (T_A=25°C unless otherwise noted)

Parameter	Symbol	Value	Unit
Peak Reverse Voltage	V_{RM}	100	V
Reverse Voltage	V_R	80	V
Average Rectified Forward Current	$I_{F(AV)}$	150	mA
Forward Continuous Current	I_{FM}	300	mA
Non-Repetitive Peak Forward Surge Current (at t = 1 μs)	I_{FSM}	0.5	A
Power Dissipation	P_d	200	mW
Junction Temperature	T_j	150	°C
Storage Temperature Range	T_{stg}	- 65 to + 150	°C

Electrical Characteristics (T_A=25°C unless otherwise noted)

Parameter	Symbol	Min.	Max.	Unit
Forward Voltage at I _F = 5 mA at I _F = 10 mA at I _F = 100 mA at I _F = 150 mA	V _F	0.62 - - -	0.72 0.855 1 1.25	V
Reverse Leakage Current at V _R = 80 V at V _R = 20 V at V _R = 75 V, T _J = 150 °C at V _R = 25 V, T _J = 150 °C	I _R	- - - -	100 25 50 30	nA nA μA μA
Reverse Breakdown Voltage at I _R = 100 μA	V _{(BR)R}	80	-	V
Total Capacitance at V _R = 0.5 V, f = 1 MHz	C _{tot}	-	4	pF
Reverse Recovery Time at I _F = I _R = 10 mA, I _{rr} = 0.1 X I _R , R _L = 100 Ω	t _{rr}	-	4	ns

Ratings and Characteristic Curves

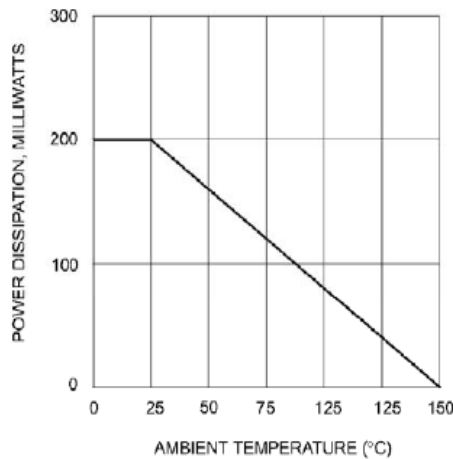

Fig. 1 Forward Current Derating Curve

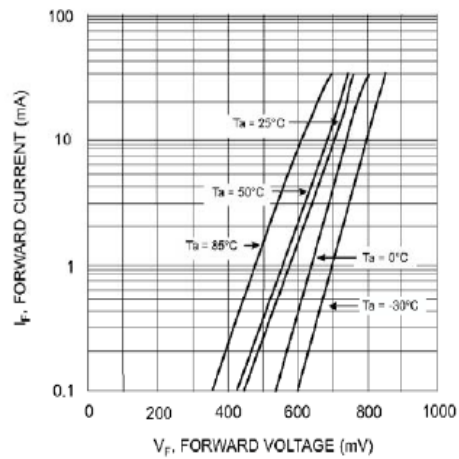

Fig. 2 Typical Forward Characteristics

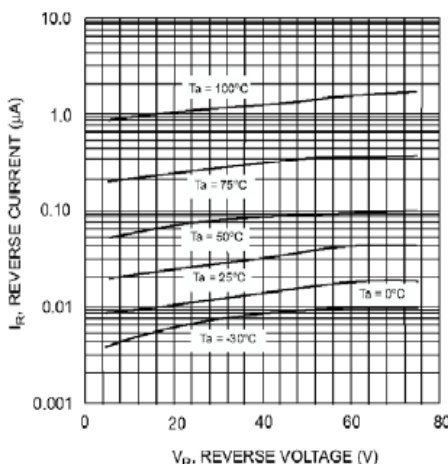

Fig. 3 Typical Reverse Characteristics

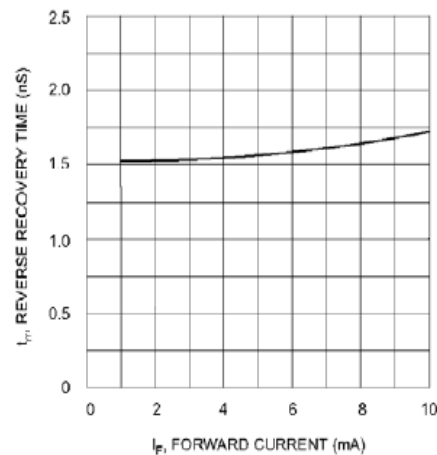

Fig. 4 Reverse Recovery Time vs. Forward Current



1N4448WS

Silicon Epitaxial Planar Switching Diode

Ordering Information

Part No.	Package	Packing Code	Packing
1N4448WS	SOD-323	R30	3000pcs/Reel

Disclaimer

Specifications of the products displayed herein are subject to change without notice. JGD or anyone on its behalf, assumes no responsibility or liability for any errors or inaccuracies.

Information contained herein is intended to provide a product description only. No license, express or implied, to any intellectual property rights is granted by this document. Except as provided in JGD's terms and conditions of sale for such products, JGD assumes no liability whatsoever, and disclaims any express or implied warranty, relating to sale and/or use of JGD products including liability or warranties relating to fitness for a particular purpose, merchantability, or infringement of any patent, copyright, or other intellectual property right.

The products shown herein are not designed for use in medical, life-saving, or life-sustaining applications. Customers using or selling these products for use in such applications do so at their own risk and agree to fully indemnify JGD for any damages resulting from such improper use or sale.