

Features

- * High Voltage Switching Diode
- * Fast switching speed
- * Surface mount package ideally suited for automatic insertion
- * Marking Code: JX

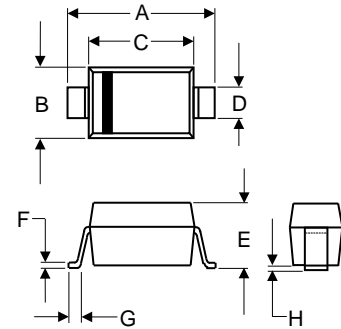

RoHS
COMPLIANT



SOD-123				
DIM	INCHES		MM	
	MIN	MAX	MIN	MAX
A	0.138	0.150	3.50	3.80
B	0.059	0.067	1.50	1.70
C	0.100	0.106	2.54	2.70
D	0.020	0.028	0.50	0.70
E	0.036	0.048	0.91	1.21
F	0.003	0.008	0.08	0.20
G	0.008	0.016	0.20	0.40
H	---	0.004	---	0.10

Maximum Ratings (T_A=25°C unless otherwise noted)

Parameter	Symbol	Value	Unit
Repetitive Peak Reverse Voltage BAV19W BAV20W BAV21W	V _{RRM}	120 200 250	V
Reverse Voltage BAV19W BAV20W BAV21W	V _R	100 150 200	V
Average Rectified Forward Current	I _{F(AV)}	200	mA
Forward Continuous Current	I _{FM}	400	mA
Repetitive Peak Forward Current	I _{FRM}	625	mA
Non-repetitive Peak Forward Surge Current at t = 1 ms at t = 1 s	I _{FSM}	2.5 0.5	A
Power Dissipation	P _d	250	mW
Operating and Storage Temperature Range	T _j / T _{stg}	- 65 to + 150	°C

Electrical Characteristics (T_A=25°C unless otherwise noted)

Parameter	Symbol	Min.	Max.	Unit
Forward Voltage at I _F = 100 mA at I _F = 200 mA	V _F	- -	1 1.25	V
Reverse Breakdown Voltage at I _R = 100 μA BAV19W BAV20W BAV21W	V _{(BR)R}	120 200 250	- - -	V
Reverse Current at V _R = 100 V at V _R = 150 V at V _R = 200 V	I _R	- - -	100 100 100	nA
Total Capacitance at V _R = 0, f = 1 MHz	C _T	-	5	pF
Reverse Recovery Time at I _F = I _R = 30 mA, I _{rr} = 0.1I _R , R _L = 100 Ω	t _{rr}	-	50	ns

Ratings and Characteristic Curves

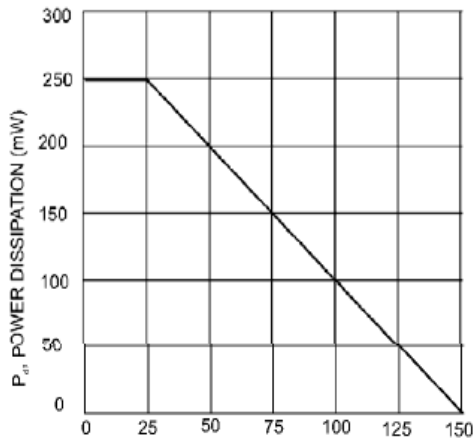

T_A AMBIENT TEMPERATURE (°C)
Fig. 1 Power Derating Curve

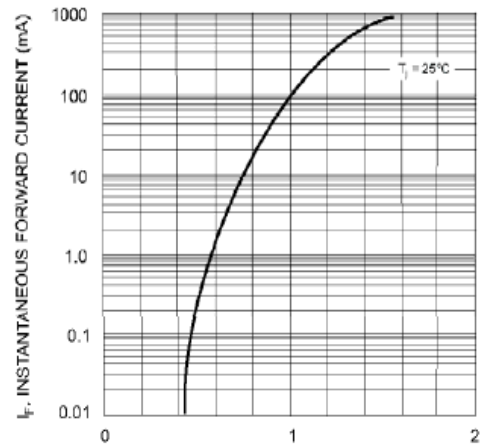

V_F INSTANTANEOUS FORWARD VOLTAGE (V)
Fig. 2 Typical Forward Characteristics

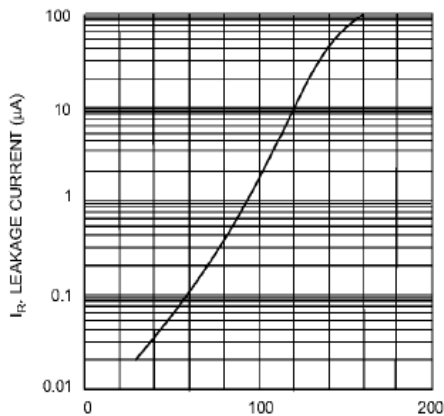

T_J JUNCTION TEMPERATURE (°C)
Fig. 3 Leakage Current vs. Junction Temperature



BAV19W, BAV20W, BAV21W Silicon Epitaxial Planar Diodes

Ordering Information

Part No.	Package	Packing Code	Packing
BAV19W, BAV20W, BAV21W	SOD-123	R30	3000pcs/Reel

Disclaimer

Specifications of the products displayed herein are subject to change without notice. JGD or anyone on its behalf, assumes no responsibility or liability for any errors or inaccuracies.

Information contained herein is intended to provide a product description only. No license, express or implied, to any intellectual property rights is granted by this document. Except as provided in JGD's terms and conditions of sale for such products, JGD assumes no liability whatsoever, and disclaims any express or implied warranty, relating to sale and/or use of JGD products including liability or warranties relating to fitness for a particular purpose, merchantability, or infringement of any patent, copyright, or other intellectual property right.

The products shown herein are not designed for use in medical, life-saving, or life-sustaining applications. Customers using or selling these products for use in such applications do so at their own risk and agree to fully indemnify JGD for any damages resulting from such improper use or sale.